



High Mount
Outdoor Detector
HX-80N/BONAM

WIRED MODEL

HX-80N	2 PIRs standard model
HX-80NAM	HX-80N with anti-masking

FEATURES

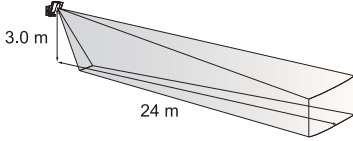

HX series with OPTEX's unique pyro-element provide; Highly reliable detection and performance against false or missed alarms. Stable and accurate detection in outdoor severe environment.

- Long distance detection area (24 m)
- Flexible detection area setting with plates and flaps
- Unique pyro element
- Intelligent AND logic
- Dual signal processing logic
- Vegetation sway analysis logic
- Digital anti-masking (AM model)

CONTENTS

1 INTRODUCTION	
1-1 BEFORE YOUR OPERATION	1
1-2 PARTS IDENTIFICATION	2
2 DETECTION AREA	
2-1 OUTLINE OF DETECTION AREA	3
2-2 HOW TO REDUCE THE LONG RANGE DETECTION AREA	4
2-3 HOW TO DEACTIVATE THE SHORT RANGE DETECTION AREA	5
3 INSTALLATION	
3-1 MOUNTING WITH THE BRACKET	6
3-2 ADJUSTING THE VERTICAL ANGLE	7
3-3 MOUNTING WITHOUT THE BRACKET	8
3-4 WIRING	8
3-5 WALL TAMPER (OPTION)	9
4 WALK TEST	10
5 SETTING	10
6 LED INDICATION	11
7 SPECIFICATIONS	
7-1 SPECIFICATIONS	12
7-2 DIMENSIONS	12

1 INTRODUCTION

1-1 BEFORE YOUR OPERATION

	Failure to follow the instructions provided with this indication and improper handling may cause death or serious injury.
	Failure to follow the instructions provided with this indication and improper handling may cause injury and/or property damage.

The check mark indicates recommendation. The nix sign indicates prohibition.

Do not repair or modify product	Keep product away from water	Mount the unit securely

ENGLISH

FRANÇAIS

DEUTSCH

ITALIANO

ESPAÑOL

PORTUGUÊS

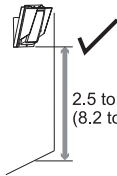
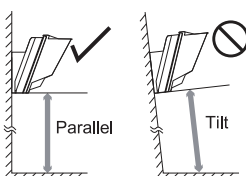
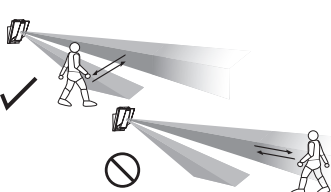
<p>Mounting height</p>  <p>2.5 to 3.0 m (8.2 to 10 ft.)</p>	<p>Keep the detector parallel to the ground.</p>  <p>Parallel</p> <p>Tilt</p>	<p>Consider the direction of the intruder, for the setting of the detection area.</p> 
--	--	--

Install the detector in a place where it is free from false alarm factors. For example:

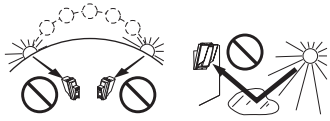
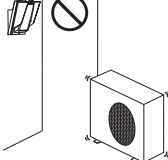
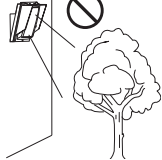
<p>• Sunlight and reflection</p> 	<p>• Heat source</p> 	<p>• Objects moving in the wind</p> 
--	--	---

1-2 PARTS IDENTIFICATION

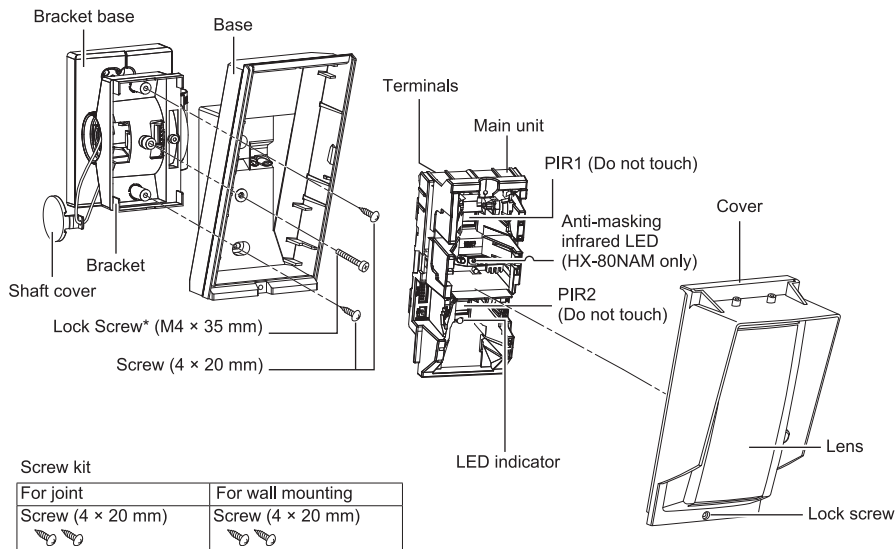

Bracket base

Base

Bracket

Shaft cover

Lock Screw* (M4 × 35 mm)

Screw (4 × 20 mm)

Terminals

Main unit

PIR1 (Do not touch)

Anti-masking infrared LED (HX-80NAM only)



PIR2 (Do not touch)

LED indicator

Cover

Lens

Lock screw

Screw kit	
For joint	For wall mounting
Screw (4 × 20 mm)	Screw (4 × 20 mm)
	

*Lock screw attached on bracket base

2 DETECTION AREA

2-1 OUTLINE OF DETECTION AREA

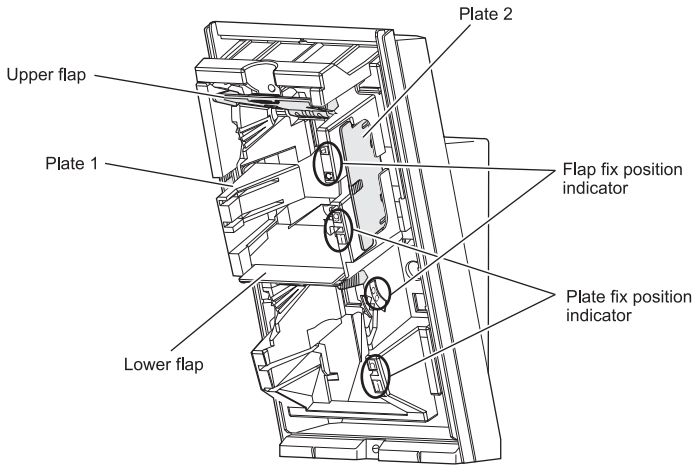

DETECTION AREA (factory default)

Side View

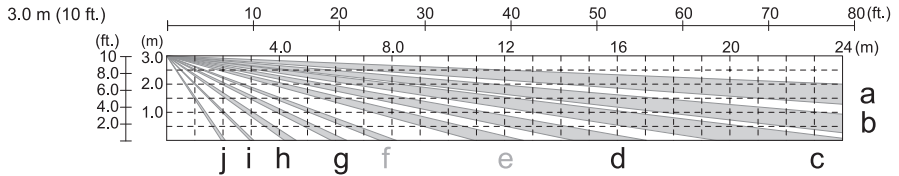

Caution>>

• Adjust 1 click (1.25° upward) for 3.0 m (10 ft.) height installation. (Refer to 3-2)

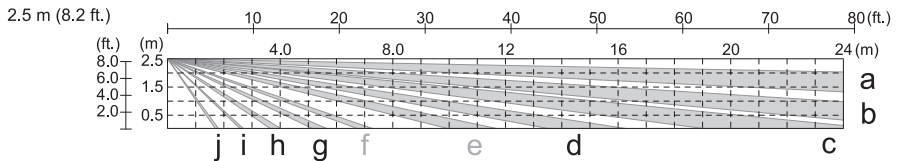

Caution>>

• Adjust 2 clicks (2.5° upward) for 2.5 m (8.2 ft.) height installation. (Refer to 3-2)

Top View

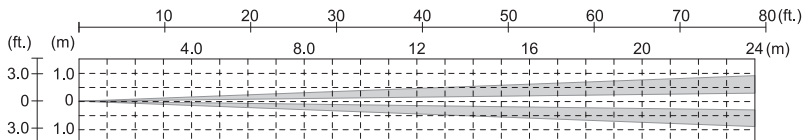

2-2 HOW TO REDUCE THE LONG RANGE DETECTION AREA

To adjust the LONG range of detection, set the upper and lower flaps as follows:

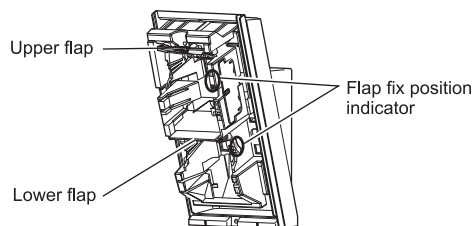

- 1 Pull out the flap.

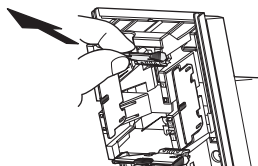

Note>>

If the lower flap is located at the factory default position, slide it out with your thumb.

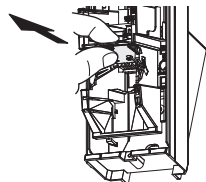

- 2 Move the flap to the position that corresponds with the desired detection distance.

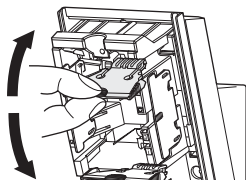

- 3 Push the flap until it clicks into position.

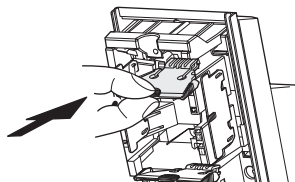

PIR long range detection area reduction

The detection distance in the following table can be limited by combining the positions of the flap. Use the following table to determine the positions of the upper and lower flaps that set the required max. detection distance.

NOTES:

1. The distance may vary due to environmental conditions.
2. Always walk test the detector to confirm the detection distance.

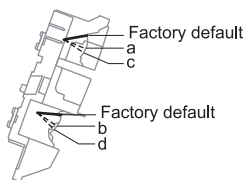

NOTE: Use only the following combinations for the flap settings.

Lower \ Upper	Factory default	b	d
Factory default	24 m (80 ft.)	N.A.	N.A.
a	① 18 m (60 ft.)	② 13 m (43 ft.)	N.A.
c	N.A.	③ 10 m (33 ft.)	④ 6,5 m (22 ft.)

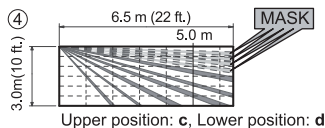
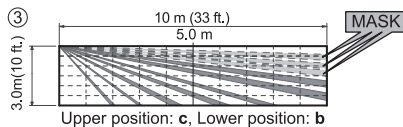
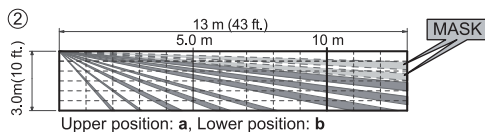
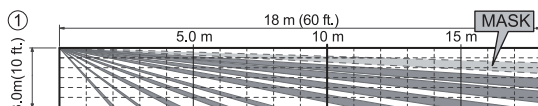

2-3 HOW TO DEACTIVATE THE SHORT RANGE DETECTION AREA

To adjust the SHORT range of detection, set the upper and lower plates follows:

1 Remove the plate.

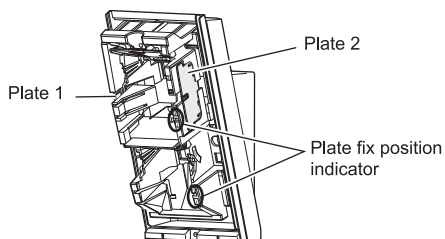

* Plate 1 and 2 are identical.

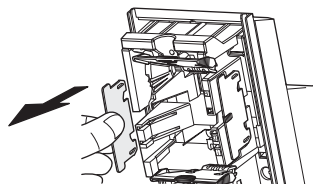

2 Insert the plate into the position determined by the required masking distance until it clicks.

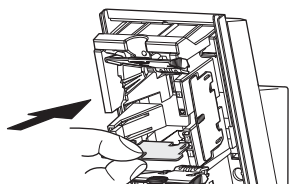

3 If any plate is not used, place it in the storage position.

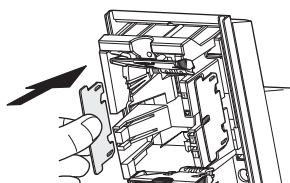

Note>>
Be careful not to lose the plates.

PIR short range detection area deactivation

Use the following table to determine the positions of the plates that set the required masked area.

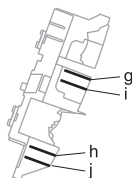

NOTE: Use only the following combinations for the plate settings.

Lower \ Upper	Not used	j	h
Not used	Factory default	①	N.A.
i	N.A.	②	③
g	N.A.	N.A.	④

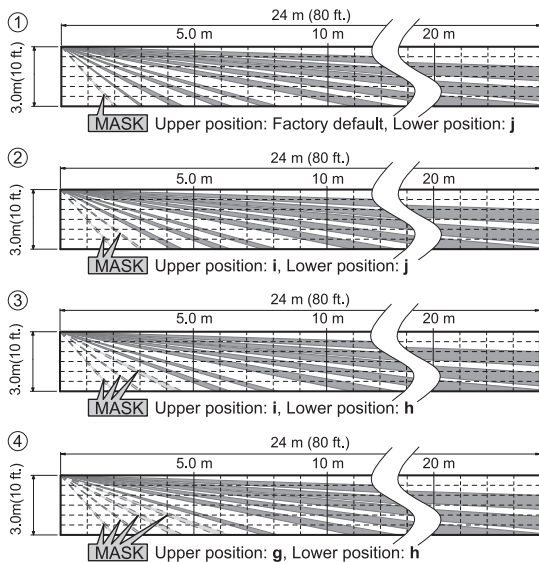

3 INSTALLATION

Use the bracket for normal installation. The unit may be installed directly on the wall, without the bracket, only if the following three conditions are met;

- The mounting height is less than 3.0 m (10 ft.).
- Horizontal adjustment is not necessary.
- The ground must be level.

3-1 MOUNTING WITH THE BRACKET

Using the bracket makes it possible to adjust the unit horizontally by $\pm 90^\circ$.
 In cases where the ground is uneven and therefore not parallel with the base of the unit, it is possible to adjust the unit vertically by $\pm 20^\circ$.

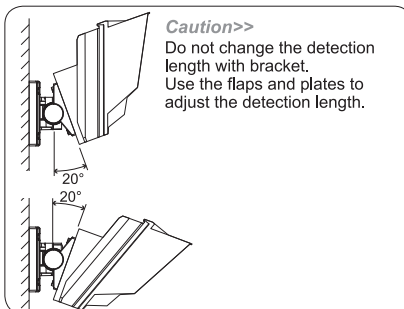
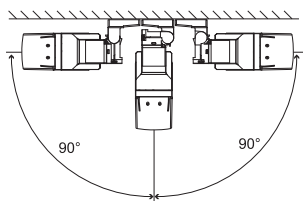

Caution>>
 Do not change the detection length with bracket.
 Use the flaps and plates to adjust the detection length.

- 1** Remove the Up-Down lock screw.

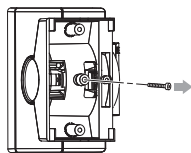

- 2** Push the shaft cover clip straightly to remove the shaft cover.

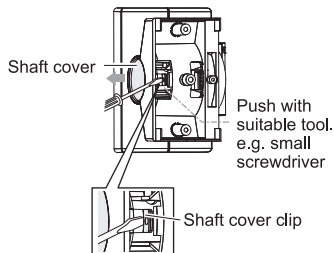

- 3** Loosen the adjustment screw two turns.

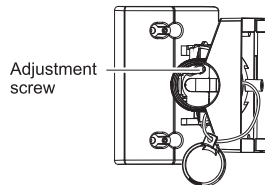

Caution>>
 Do not loosen the screw too much.
 It may disassemble.

- 4** Tilt the bracket about 45° and pass through the wire.

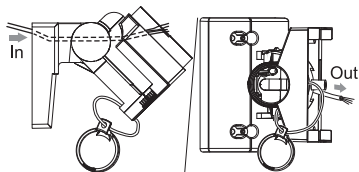

- 5** Determine the horizontal direction (left or right) of the detector before installing the bracket on the wall.

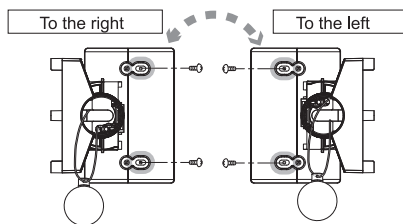

- 6** Open the wiring knockout.

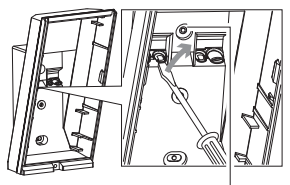

Wiring knockout

- 7** Open the Up-Down lock screw knockout for connecting the bracket.

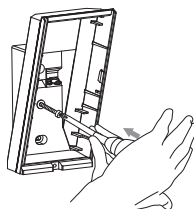

Knockout with 4x20 tapping screw (screwkit)

- 8 Tighten screws ① and ②, adjust the bracket angle (refer to 3-2), then tighten screw ③. Perform an area check. If re-adjustment is required, loosen screw 3 and change the bracket angle. After the adjustment is complete, tighten screw ③ again.

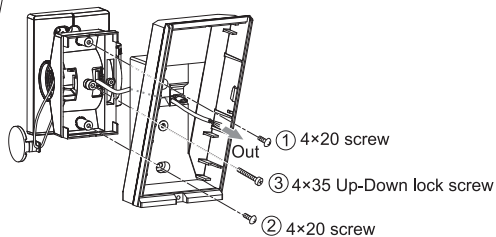
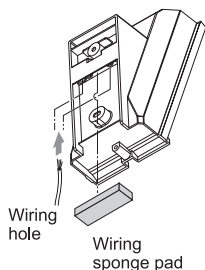

- 9 Tighten the adjustment screw clockwise.

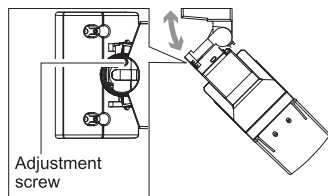

- 10 Wire to the terminal and install the main unit and lens on the base.

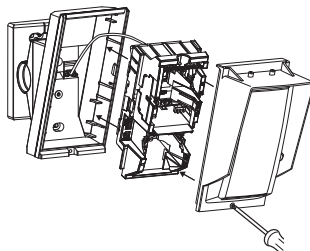

- 11 Install shaft cover into place.

3-2 ADJUSTING THE VERTICAL ANGLE

For best performance, install detector parallel to the ground. Decide the detection length. To change the detection length, adjust the flap and plate positions. Refer to the 2-2, 2-3 for the details.

Perform walk test to ensure detector is parallel to the ground.

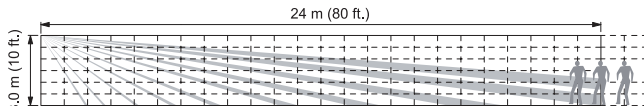

* This description assumes the detection length to be 0 m (0 ft.) to 24 m (80 ft.).

If the detection length is shorter than the intentional (refer to ②), change the detector angle upwards.

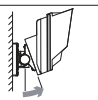

If the detection length is longer than the intentional (refer to ②), change the detector angle downwards.



If the detection length is enough to the intentional (refer to ②), the adjustment is complete.

Example>>

If the ground is level, no need to adjust. (0° is the origine.)

Adjust 2 clicks (2.5° upward) for 2.5 m (8.2 ft.) height installation.

Adjust 1 click (1.25° upward) for 3.0 m (10 ft.) height installation.

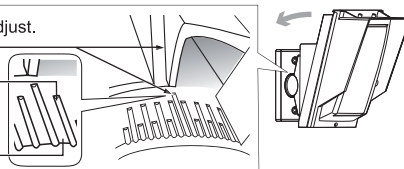

3-3 MOUNTING WITHOUT THE BRACKET

1 Open the wiring knockout with suitable tool e.g. screwdriver.

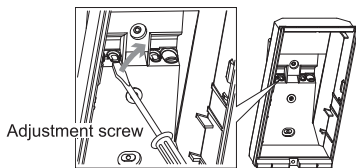

2 Pull the wire through the base knockout.

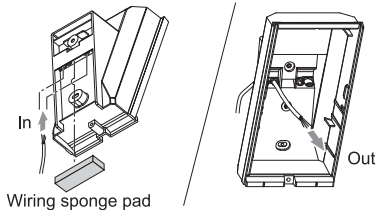

3 Fasten the base to the wall.

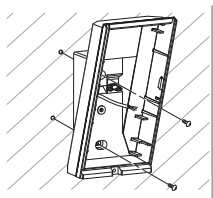

4 Install main unit after wiring to the terminal.

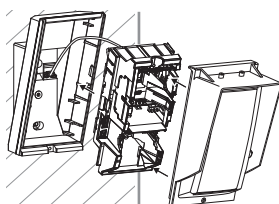

3-4 WIRING

Power wires should not exceed the following lengths.

Unit: m (ft.)

WIRE GAUGE	HX-80N		HX-80NAM	
	12 V	14 V	12 V	14 V
AWG22 (0.33 mm ²)	160 (520)	360 (1180)	140 (460)	310 (1020)
AWG20 (0.52 mm ²)	260 (850)	560 (1840)	230 (750)	490 (1610)
AWG18 (0.83 mm ²)	410 (1350)	900 (2950)	360 (1180)	780 (2560)

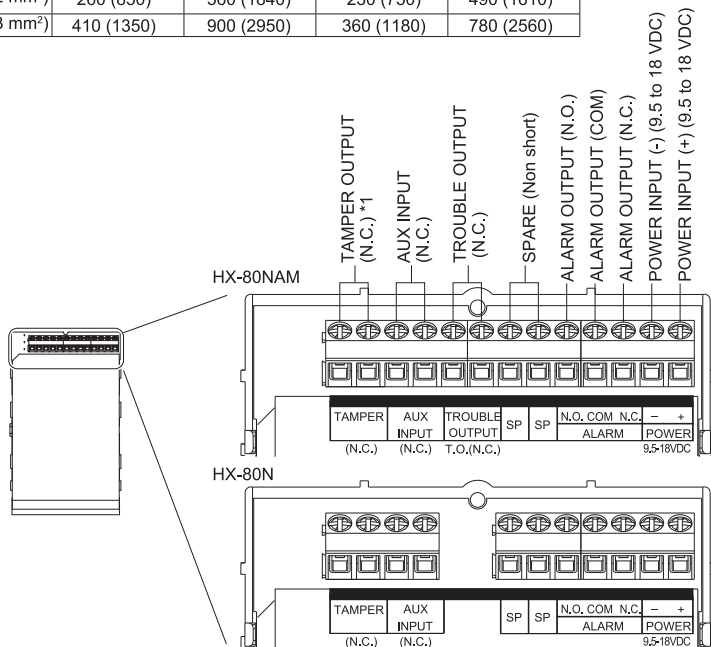

*1: TAMPER terminals to be connected to a 24 hour supervisory loop.

3-5 WALL TAMPER (OPTION)

ENGLISH

FRANÇAIS

DEUTSCH

ITALIANO

ESPAÑOL

PORTUGUÊS

Universal magnet switch may be mounted as a wall tamper.
 Installation space for magnet switch is provided on the back of the main unit and the bracket.
 Maximum size of an applicable magnet switch: D 9 x W 40 x H 9 mm (D 0.35 x W 1.57 x H 0.35 inches)
 Magnet switch is not included.

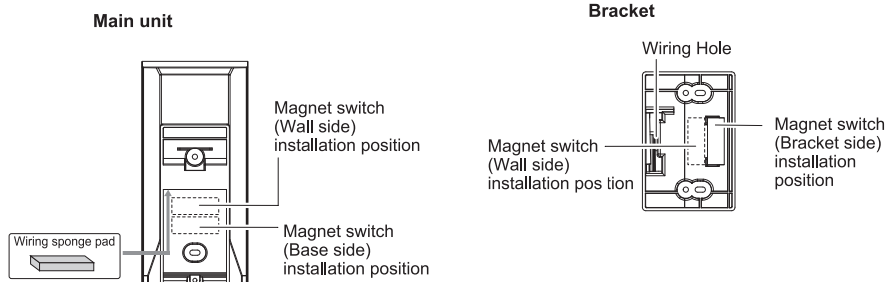

-Installation

- 1 Install the magnet switch (wall side) to the wall. To determine the installation position, use the "Installation position template" provided on the inside cover of the product package.
- 2 Open the wiring knockout with suitable tool e.g. screwdriver.

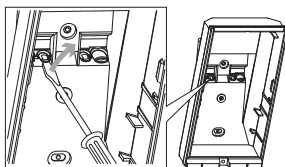
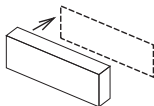

- 3 Install the other portion of the magnet switch to the back of the main unit or the bracket. Pull the wiring through the knockouts.

When not using the bracket

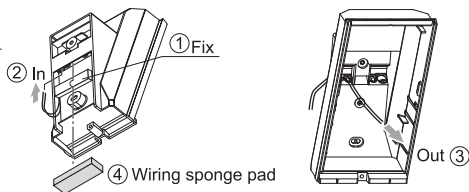

When using the bracket

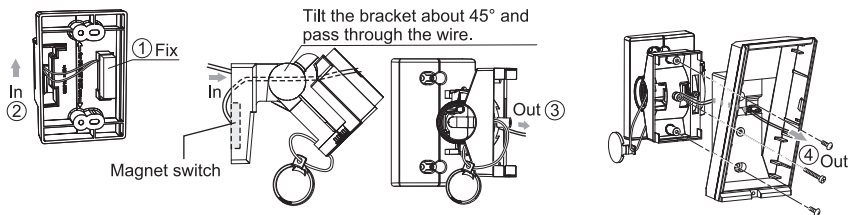

- 4 Install the bracket and the main unit to the walls surface.
- 5 Connect the magnet switch wiring to the tamper terminal of the main unit.

4 WALK TEST

- 1 Set the DIP switch 1 (LED ON/OFF) to "ON".

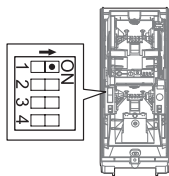

Note>>

The switch is set "ON" by factory default.

- 2 Check that the detector detects an object in the intended detection area. The installation has been successful if the LED lights for two seconds after a person walks into the detection area.

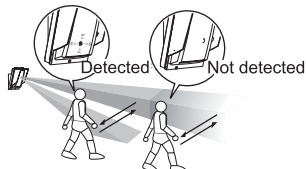

Note>>

- For the walk test, move more than 1.0 m (3.3 ft.) away from the detector.
- Conduct a walk test at least once a year.

- 3 If the LED indication is not required at all times, set the DIP switch 1 (LED ON/OFF) to "OFF".

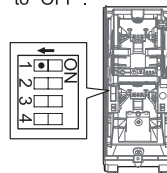

5 SETTING

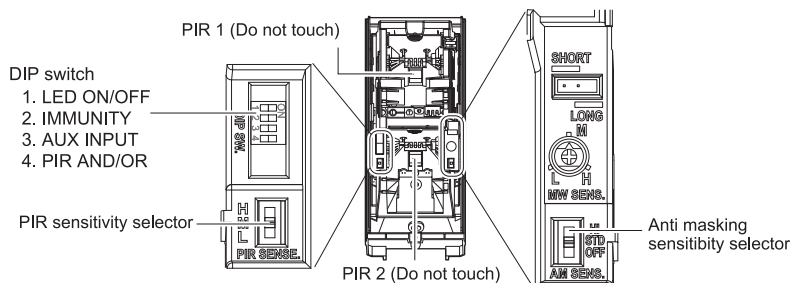

-LED ON/OFF



OFF ↔ ON

POSITION	FUNCTION
ON (Factory default)	The LED lights when someone is detected.
OFF	The LED does not light even if someone is detected.

DIP switch 1

HX-80N
HX-80NAM

-IMMUNITY



STD ↔ IMMUNITY

POSITION	FUNCTION
STD (Factory default)	IMMUNITY logic is not activated.
IMMUNITY	IMMUNITY logic is activated. Use this under harsh environment (e.g. vegetation sway).

DIP switch 2

HX-80N
HX-80NAM

-AUX INPUT



AND ↔ OR

By connecting a secondary unit (another warning sensor), you can extend the detection area and correct false alarms. The secondary unit must have a voltage free N.C. output such as another PIR detector or AIR detector.
<Infrared (AIR) sensors, thermal line (PIR) sensors, magnet switches, etc.>

POSITION	FUNCTION
AND (Factory default)	When both the main unit and the secondary detect someone, the alarm is activated. Choose this setting when a secondary unit is not connected.
OR	When either the main unit or the secondary detects someone, the alarm is activated.

DIP switch 3

HX-80N
HX-80NAM

Notes>>

- The alarm is only activates if both the main unit and the secondary unit are activated within 60 sec.
- In OR mode, a secondary detector must be fitted. If not fitted, the unit will generate an alarm continuously.

-PIR AND/OR

DIP switch 4

HX-80N
HX-80NAM

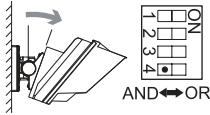

POSITION	FUNCTION
AND (Factory default)	An alarm is output when both PIR1 and PIR2 detect an object.
OR	An alarm is output when either PIR1 or PIR2 detects an object. Selecting "OR" mode makes detection range longer than "AND" mode. Walk test to readjust the detection range is required when "OR" is selected. <u>Actual adjustment should be conducted by adjusting the bracket angle.</u>



Note>>

"OR" mode is appropriate for the sites that require more detectability rather than false alarm tolerance such as lighting control and camera activation.

-PIR SENSITIVITY

PIR SENSITIVITY SELECTOR

HX-80N
HX-80NAM

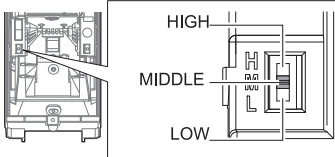

POSITION	FUNCTION
HIGH	High sensitivity
MIDDLE (Factory default)	Middle sensitivity
LOW	Low sensitivity

-ANTI-MASKING SENSITIVITY

ANTI-MASKING SENSITIVITY SELECTOR

HX-80N
HX-80NAM

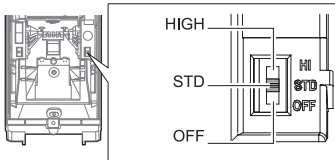

POSITION	FUNCTION
HIGH	High sensitivity
STD (Factory default)	Normal sensitivity
OFF	Disabled

Caution>>

After closing the cover, do not leave any objects closer than 1 meter from the unit.

6 LED INDICATION

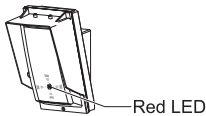

DETECTOR CONDITION		LED INDICATOR (RED ONLY)
Warm-up		Blinks for approx. 60 sec.
Alarm		Lights for 2 sec.
Trouble output (HX-80NAM only)	Anti-Masking booting (Anti-Masking start up)	Blinks 2 times and goes off for 5 sec. and then repeats for 180 sec.
	Masking detection	Blinks 3 times and goes off for 3 sec. and then repeats.

7 SPECIFICATIONS

7-1 SPECIFICATIONS

Model	HX-80N	HX-80NAM
Detection method	Passive infrared	
PIR Coverage	24 m × 2.0 m (80 ft. × 6.6 ft.) narrow / 20 zones	
PIR distance limit	6.5 m, 10 m, 13 m, 18 m (22 ft., 33 ft., 43 ft., 60 ft.)	
Detectable speed	0.3 to 1.5 m/s (1 to 5 ft./s)	
Sensitivity	2.0°C (3.6°F) at 0.6 m/s	
Power input	9.5 to 18 VDC	
Current draw	35 mA (max.) at 12 VDC	40 mA (max.) at 12 VDC
Alarm period	2.0 ±1 sec.	
Warm-up period	Approx. 60 sec. (LED blinks)	
Alarm output	Form C 28 VDC 0.2 A (max.)	
Tamper output	N.C. 28 VDC, 0.1 A (max.) open when cover removed.	
Trouble output	-	N.C. 28 VDC, 0.1 A (max.)
Aux input	N.C. 28 VDC, 0.1 A (max.)	
LED indicator	Red: Warm-up, Alarm	Red: Warm-up, Alarm, Trouble
Operating temperature	-20°C to +60°C (-4°F to +140°F)	
Environment humidity	95% max.	
Weatherproof	IP55	
Mounting	Wall	
Mounting height	2.5 to 3.0 m (8.2 to 10 ft.)	
Bracket adjust angle	Vertical: ±20° Horizontal: ±95°	
Weight	720 g (25.4 oz.)	
Accessories	Bracket, Screw (4 × 20 mm) × 4	

* Specifications and designs are subject to change without prior notice.

7-2 DIMENSIONS

Using bracket

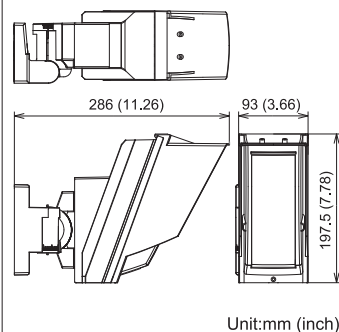

Without bracket

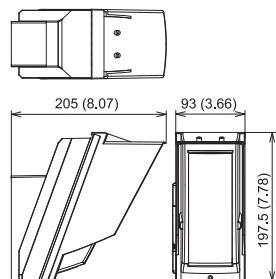

The HX-80N series is only a part of a complete system, therefore we cannot accept complete responsibility for any damages or other consequences resulting from an intrusion.

■ EU contact information

Manufacturer:

OPTEX CO., LTD.
5-8-12 Ogoto, Otsu, Shiga, 520-0101 JAPAN

Authorised representative in Europe:

OPTEX (EUROPE) LTD. / EMEA HEADQUARTERS
Marandaz House 1 Cordwallis Park, Clivernot Road,
Maidenhead, Berkshire, SL6 7BU U.K.



OPTEX CO., LTD. (JAPAN)

URL: <http://www.optex.net>

OPTEX INC. (U.S.)

URL: <http://www.optexamerica.com>

OPTEX DO BRASIL LTDA. (Brazil)

URL: <http://www.optex.net/br/es/sec>

OPTEX (EUROPE) LTD. / EMEA HQ (U.K.)

URL: <http://www.optex-europe.com>

OPTEX TECHNOLOGIES B.V.(The Netherlands)

URL: <http://www.optex.eu>

OPTEX SECURITY SAS (France)

URL: <http://www.optex-security.com>

OPTEX SECURITY Sp.z o.o. (Poland)

URL: <http://www.optex.com.pl>

OPTEX PINNACLE INDIA, PVT., LTD. (India)

URL: <http://www.optex.net/in/en/sec>

OPTEX KOREA CO.,LTD. (Korea)

URL: <http://www.optexkorea.com>

OPTEX (DONGGUAN) CO.,LTD.

SHANGHAI OFFICE (China)
URL: <http://www.optexchina.com>

OPTEX (Thailand) CO., LTD. (Thailand)

URL: <http://www.optex.net/th/th>

Copyright (C) 2016 OPTEX CO.,LTD.